



## BROADBAND VECTOR CHANNEL SOUNDER FOR MIMO CHANNELS

### Introduction

3G and 4G mobile communication systems consider multiple antennas at both receiver and transmitter for reaching enhanced channel capacity at well defined quality of service. Perfect design of such systems requires profound knowledge of the radio channel, especially its time-variant characteristics in various radio environments. A precise characterization of the radio channel is given by the vector channel impulse response (VCIR). In Multi Input Multiple Output (MIMO) systems the VCIR is measured for each transmitting antenna to a configured RX antenna array. The time variance of the radio channel requires high speed recording of VCIRs with respect to the maximum Doppler frequency. The presented vector channel sounder covers all MIMO aspects. Up to 256 MIMO channels can be configured by software. Broadband technique grants for high time resolution. Superresolution techniques can be used for joint estimation of time delay, direction of arrival and direction of departure with respect to multipath propagation. The measurement data can be used directly (as stored radio channel) as well as indirectly (as derived channel model) for realistic link- and system- level simulation.

### MIMO Channels

MIMO channels have been investigated by theoretical studies. Major benefits are expected in enhancement of channel capacity, extension of range and reduction of interference. In rich scattering environments multipath propagation excites many spatial channels between each transmit and receive antenna element, which can be exploited by spatial signal processing e.g. to increase bit rate at the same bandwidth. For validation of theoretical approaches under practical conditions multi channel measurements are essential.

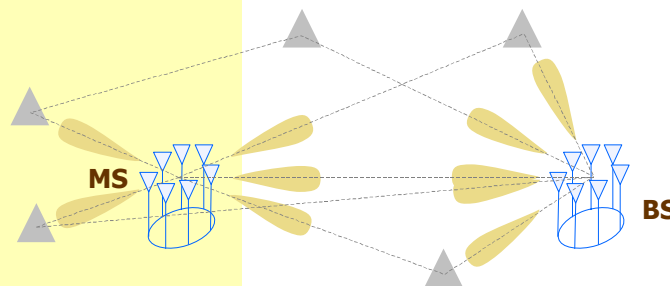

Figure 1: MIMO channel environment

Deployment of antenna arrays at mobile station (MS) and base station (BS) provide the platform for multi dimensional channel analysis. Further to SISO channels where omni-directional antennas at MS and BS are used, angles of outgoing and incoming waves can be estimated. The multi path radio channel can be characterized by Direction of Departure (DoD), Direction of Arrival (DoA) and corresponding Time-Delay of Arrival and Doppler Shift. New spatial channel models have to be derived for application in realistic link- and system- level simulation.

### Design Aspects for MIMO Channel Sounding

Real-time acquisition of the vector channel impulse responses (VCIR) is required for correct estimation of Doppler-shifted paths and for complete retrieval of path statistics. Real-time acquisition means the repetition rate of VCIR snapshots has to be high enough in order to reproduce the time variation by meeting the Nyquist criterion with respect to the maximum Doppler bandwidth. This criterion is especially important in case multiplexing technique is applied for antenna switching.

Traditional measurement methods based on swept network analyzers, direct RF pulse technique or sliding correlator and rotating antennas do generally not cover MIMO requirements. A good approach to eliminate the disadvantages of traditional sounders is correlation technique, using pseudo noise sequences (PN) or real time sampled sequences (RTS).

The measurement principle of PN and RTS is similar. The transmitter provides a periodic test sequence. In the receiver the arriving test signal is correlated with a local copy of the test sequence. Due to the impulse-like auto correlation function of the test sequence, the correlator output provides the measured channel impulse response.

For RTS the samples of a periodic test sequence (correlation signal) are designed for the specified measurement bandwidth at minimum crest factor. An arbitrary waveform generator provides a continuous TX signal by periodic output of the test sequence.

The periodic test signals represent samples of a bandlimited multifrequency signal, the measurement bandwidth is adjusted by software. Due to implicit band limitation by signal design there is generally no special need for additional analog filtering.

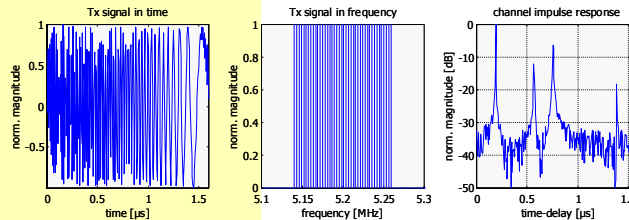

Figure 2: Channel Excitation by periodic multifrequency test signals

In figure 2 an example for a 120 MHz broadband test signal at a center frequency of 5,2 GHz is given in time and frequency domain.

Design of new measurement equipment must well consider technical requirements but also costs. For measurement of multiple channels it seems very reasonable to apply multiplexing technique instead of building up parallel hardware branches, to keep costs moderate. However it has to be assured that the Nyquist criterion with respect to Doppler bandwidth is covered and additional compensation effort for time delay may be required. For multiplexed channels interpolation filter (offline analysis) take care for correct phase alignment and thus correct DoA and DoD estimation.

### MIMO Channel Sounding

The presented broadband MIMO channel sounder applies correlation technique. It excites the radio channel by a broadband multi-tone test signal at the radio frequency. The test signal is designed for the specified bandwidth. The length of the test signal is adjustable, it corresponds to the observation time of the radio channel. An arbitrary waveform generator outputs the test signal to the up converter and power amplifier. The transmit signal is distributed to the transmit antennas by fast multiplexing.

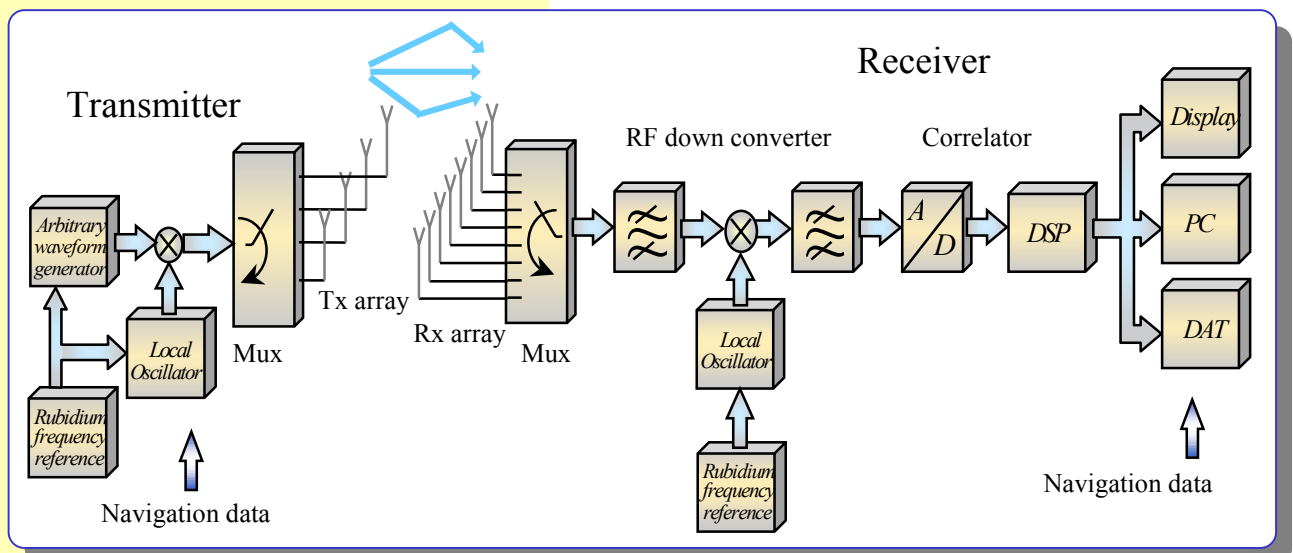

Figure 3: Principle of MIMO Channel Sounding

Fast multiplexing is also employed at the antenna array of the receiver. After bandpass filtering the receiver downconverts the resulting RF signal to an intermediate frequency. After A/D conversion the digitized IF signal is processed by DSP and then stored directly to hard disc or DAT for offline analysis. Synchronization of the clock signals is achieved by use of well adjusted Rubidium frequency references. Absolute phase stability between receiver and transmitter can be achieved by synchronization with optical fiber. Navigation data (from

GPS and/or odometer sensors) are added to the measurement data to catch the measurement positions of the collected channel impulse responses. Due to the multiplexing principle the individual antenna responses of receive and transmit array elements are sequentially estimated and stored as vector channel impulse snapshots. The multiplex timing has to be well synchronized to the periodicity of the test signal. The following diagram shows the switching scheme.

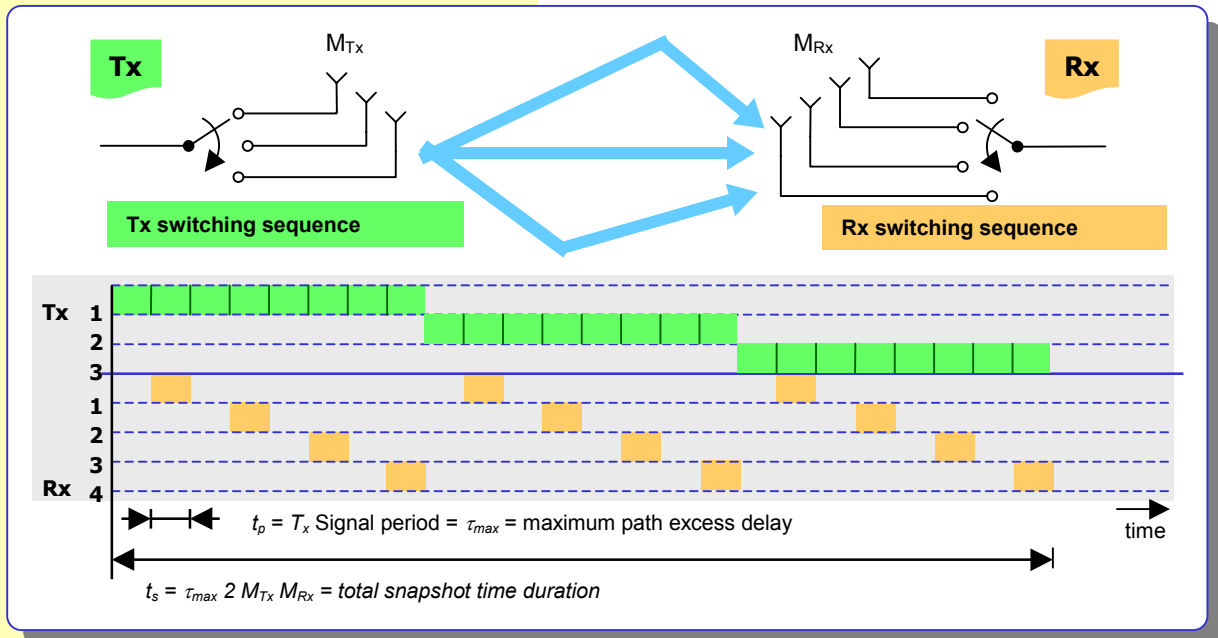

Figure 4: example for MIMO switching

Figure 4 illustrates the MUX switching scheme for 3 transmit and 4 receive antennas. Switching is synchronized to the signal period  $t_p$  (or  $\tau_{max}$ ) of the test signal. After acquisition of each RX antenna one  $t_p$  cycle is required for antenna switching. After each RX array vector snapshot, the TX antenna is switched and again one  $t_p$  cycle is inserted. Thus the total acquisition time for a complete MIMO snapshot results in  $2 * \tau_{max} * M_{Tx} * M_{Rx} = 38,4 \mu s$  for  $1,6 \mu s$  signal period, 3 transmit and 4 receive antennas corresponding to about 26 kHz max. Doppler bandwidth. Obviously the maximum Doppler bandwidth goes down with increasing path excess delay  $\tau_{max}$  and number of channels  $M_{Tx}$ ,  $M_{Rx}$ , but is still in satisfactory range for actually discussed  $8 \times 8$  antenna configuration. Highest flexibility for real time measurement is given by e.g. 10 free programmable multiplex control lines, so up to  $2^{10}$  single antenna elements can be addressed, sharing for TX and RX switching to be programmed by software.

The vector channel measurement results can be directly interpreted as a time dependant sequence of channel impulse response estimates, resolved in the spatial domain, represented by the antenna array output.

### Real-time Receiver Architecture

Another challenging demand for MIMO Real Time Recording of VCIRs is maximization of acquisition rate along with maximization of recording capacity. This demand requires an enhanced real time receiver architecture, as depicted in figure 5. Due to the multiplexing principle, the hardware branch for RF-downconversion is one physical channel. A high speed AD-converter provides the digitized IF MUX signal for postprocessing and storage. The digitized data are organized in data blocks. In real time mode, when all MUX channels have to be streamed continuously to a mass storage, a sustained data rate of up to 320 MByte/s has to be handled. The hardware concept provides high speed memory for internal block processing. For handling the 320 MByte/s data rate fiber optic interfaces spread the data to subsystems which include rate controlled hard disc array. The recording capacity is scalable, actually up to 800 GByte. Due to the huge amount of measurement data all subsystems are combined to computer clusters. They provide software for accessing data by intelligent preprocessing and filtering.

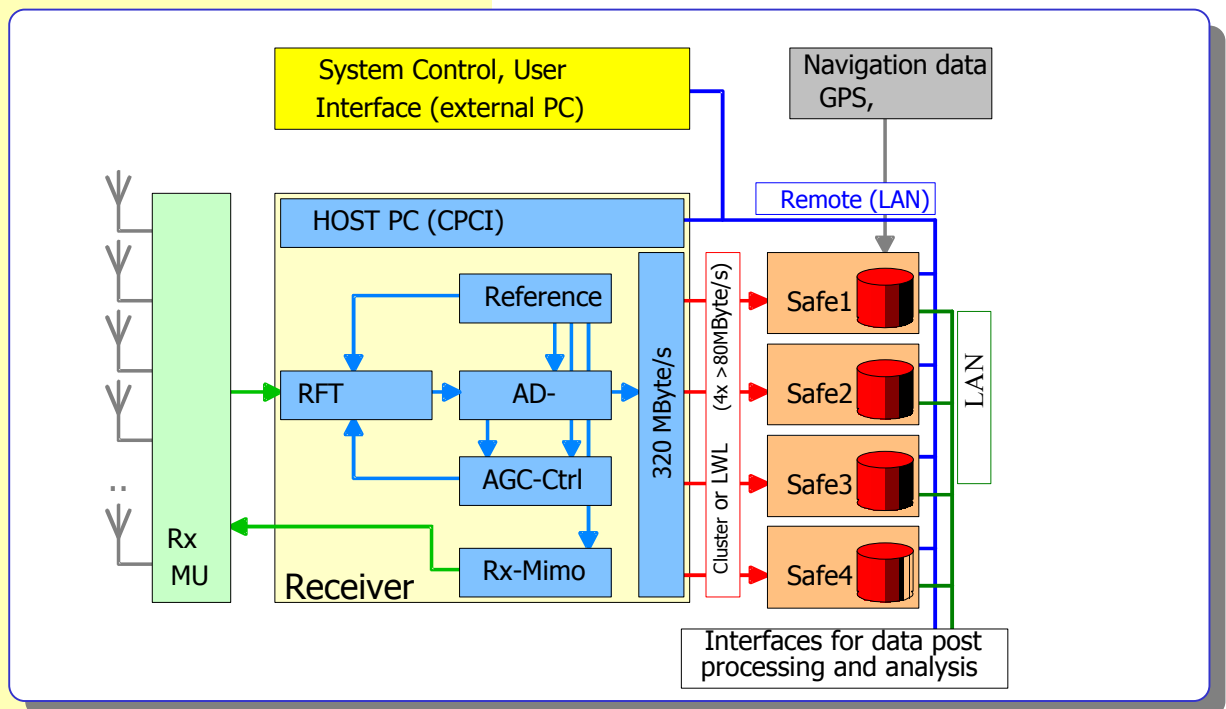

Figure 5: MIMO real time receiver architecture

## Summary

With the introduction of MIMO channel sounding, additional estimation of direction of departure at enhanced parameter resolution is possible. The antenna array multiplexing principle, well known from SIMO channel sounding can be easily extended to antenna switching at transmit side. The demand on continuous collection of channel impulse response snapshots at high measurement bandwidth with respect to maximum Doppler bandwidth requires new real time receiver architecture, which supports high storage capacity, data streaming at high sustained data rate and intelligent preprocessing.

## References

- [1] McNamara D.P., Beach M.A., Karlsson P. & Fletcher P.N., Capacity variation of Multiple-Input Multiple-Output Channels, IEE Electronics Letters, Vol. 36, No.24, 23<sup>rd</sup> November 2000, pp2037-2038. [McNamaraIEELetterNov2000]
- [2] M. Steinbauer, D. Hampicke, G. Sommerkorn, A. Schneider, A.F. Molisch, R. Thomä, E. Bonek: „Array-Measurement of the Double-Directional Mobile Radio Channel,“ IEEE Vehicular Tech. Conf., VTC2000-Spring, Tokyo, May 15-18, 2000.
- [3] F. Demmerle, W. Wiesbeck, „A biconical multibeam antenna for space-division multiple access,“ IEEE Transactions on Antennas and Propagation, vol. 46, pp. 782-787, June, 1998.
- [4] M. Haardt, „Efficient One-, Two-, and Multidimensional High-Resolution Array Signal Processing,“ Ph.D. Thesis, Shaker Verlag, Aachen, Germany, 1996.
- [5] A. Richter and R. S. Thomä, „CUBA-ESPRIT for Angle Estimation with Circular Uniform Beam Arrays,“ to appear in Proc. of Millennium Conference on Antennas and Propagation, Davos, Switzerland, April 9-14, 2000.
- [6] R.S. Thomä, D. Hampicke, A. Richter, G. Sommerkorn, A. Schneider, U. Trautwein, W. Wirtzner, „Identification of Time-Variant Directional Mobile Radio Channels,“ IMTC/99 Special Issue of IEEE Trans. Inst. and Measurement, April 2000.
- [7] K. Pensel, J.A. Nossek: „Uplink and Downlink Calibration of an Antenna Array in a Mobile Communication System“, COST 259, 3rd Meeting, 1997, September 24-26, TD-58, Lisbon, Portugal.
- [8] T. Zwick, D. Hampicke, J. Maurer, A. Richter, G. Sommerkorn, R. Thomä, W. Wiesbeck: „Results of Double Directional Channel Sounding Measurements,“ IEEE Vehicular Tech. Conf., VTC2000-Spring, Tokyo, May 15-18, 2000